

Flexible Furniture & Storage Solutions for Labs, Tech & All 'Off-Carpet' Workspace

Product Guide

Serving Northern California
with Sales & Service Across the U.S. and Overseas

Featuring



Industry leadership since 1906

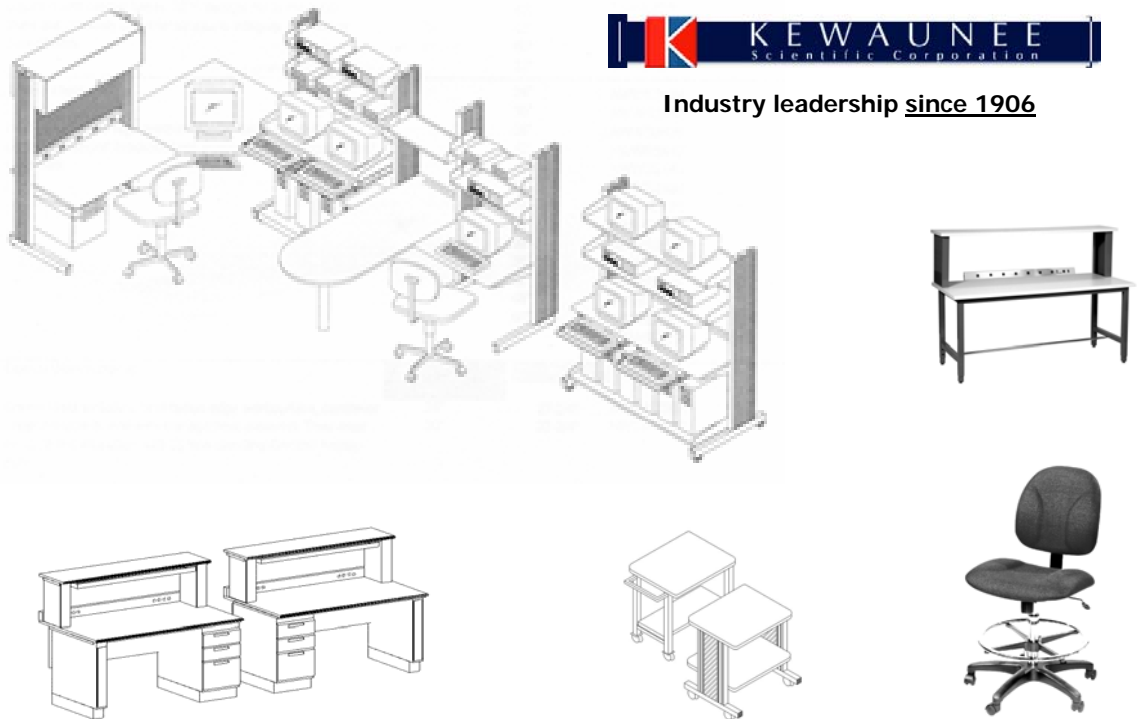

*Tech Workstations - Lab Benches - Lab Chairs/Stools
Storage Products - Production Tables - ESD/Cleanroom Products
LAN Racks/Cabinets - Training Desks - Carts - Laminar Flow Hoods
Monitor Arms - Height Adjustable Benches - Resin Tops - Shelving - Customs*

Quality Solutions for:

electronics, biotech, engineering, cleanroom, I.T., pharmaceutical, test/assembly,
ESD, data centers, medical device, manufacturing, healthcare, media, education,
telecom, security, etc. GSA & Dealer programs.

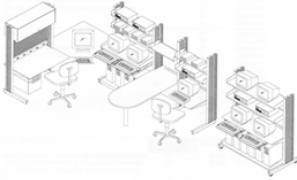

FLEXIBLE Benches & Workstations

From Kewaunee Scientific, Inc., est. 1906

Kewaunee Scientific, Inc. - est. 1906 - is one of the leading U.S. manufacturers of tech & lab furniture systems, providing a broad, *modular* product offering with focus on quality, value, flexibility, & design aesthetics. Extensive custom capability. Lifetime warranties. Competitively priced. U.L. listed electric components. 3-5 week standard lead times. Quick ship program.

Evolution™

Industry Standard - Highly flexible, highly aesthetic, modular tech bench system featuring unlimited height adjustability of worksurfaces, shelves, power strips, etc. 'Stand-alone' units include two vertical support columns. 'Add-on' units require only one column, reducing cost and adding flexibility. Column height = 76" (or 30" & 36") Vertical column provides hidden raceway for power/voice/data, etc. Individual bench widths from 3' - 6'. Std. worksurface depths of 24", 30" or 36". 150 lbs. per linear ft. load rated. Full radius front edge worksurfaces. Std. high density laminate. Chem. resistant laminate, epoxy resin, maple, and stainless steel also available. Advanced, corrosion resistant powder coat finishes meet SEFA8 standards.

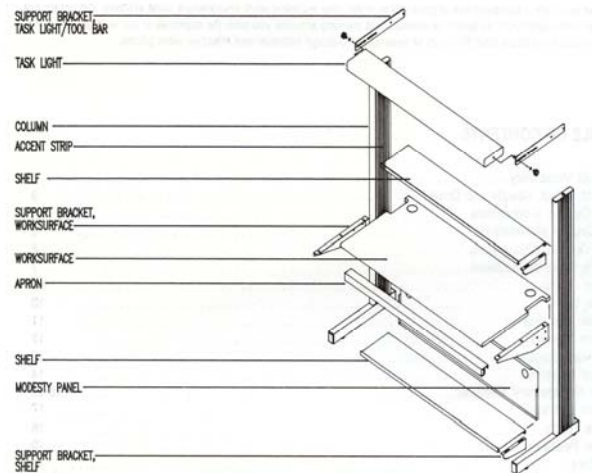

Companion System - Evolution for LANS™

Evolution™ system with integrated cable mgmt. & added features for computer intensive applications.

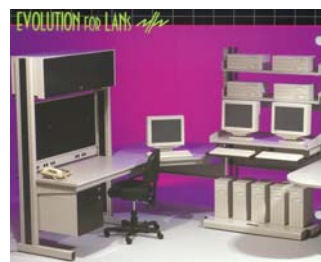

Available components for both systems include drawers, overhead storage, keyboard trays, power strips, power/voice/data, utility (gas, water, vacuum) integration, seismic bracing, etc.

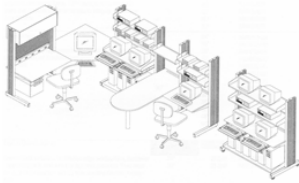

FLEXIBLE Benches & Workstations

From Kewaunee Scientific, Inc.



EvolutionTM Sample Configurations

6'w x 30''d x 76''h Stand Alone workstation, includes two vertical columns

6'w x 30''d x 76''h Add-On workstation, requires only one vertical column

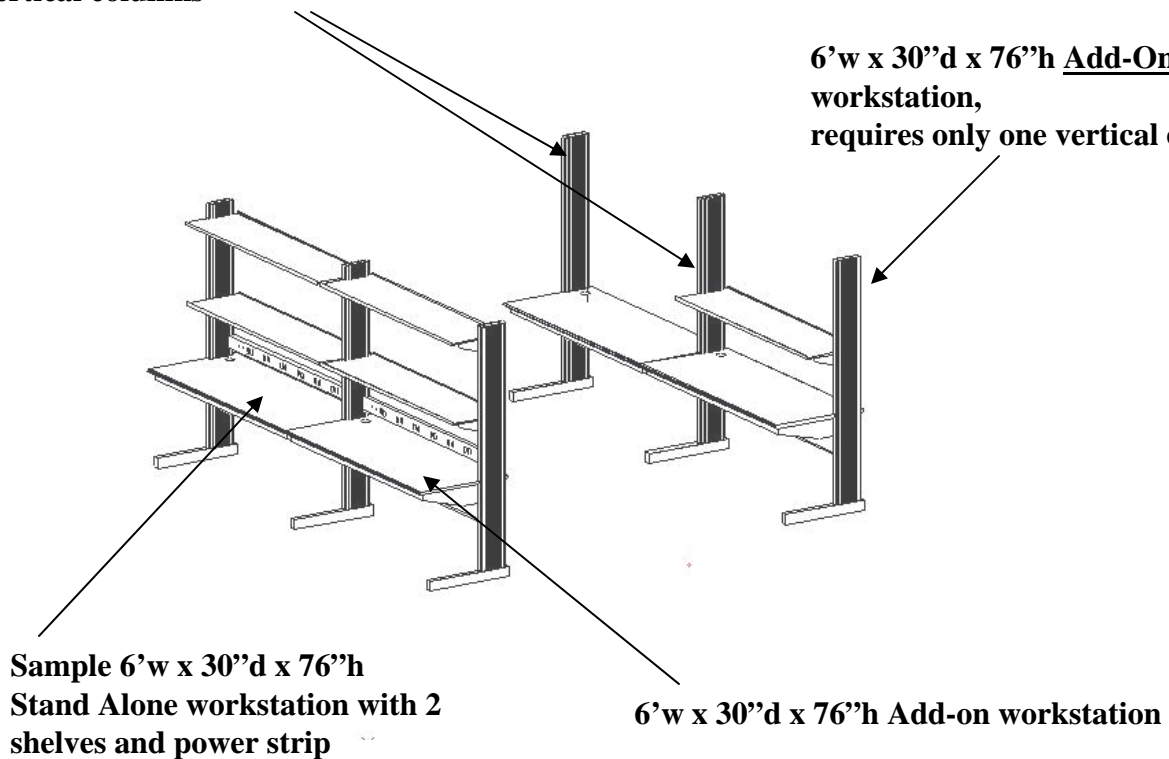

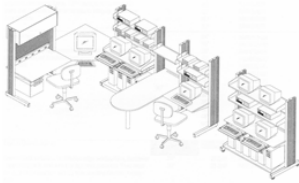

Modular design for easy
lab reconfigurations

FLEXIBLE Benches & Workstations

From Kewaunee Scientific, Inc., est. 1906



Sturdilite™

Industry Standard - Pedestal-based, fixed height lab bench system at desk or bench height, designed for long term use in virtually any environment, including labs, classrooms, medical stations, test/assembly, etc. Standard laminate, epoxy resin/chemical resistant or maple worksurfaces. Fully modular and easy to field reconfigure. 'Wet lab' quality powder coat finish on all metal surfaces. Highly aesthetic. Full radius front edge on all laminate worksurfaces. Available components include sink modules, powered backslashes/legs/shelf risers. Large selection of drawer or cabinet storage modules. Wall cabinets. Span up to 8' between supports. Mobile units. ESD systems & components available.

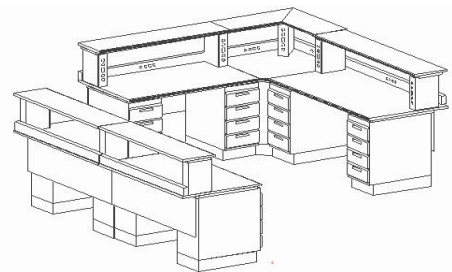
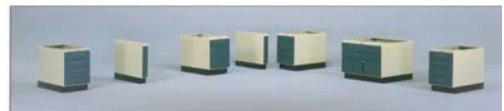

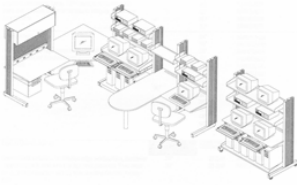

FLEXIBLE Benches & Workstations

From Kewaunee Scientific, Inc.



Sturdilite™ Sample Configurations

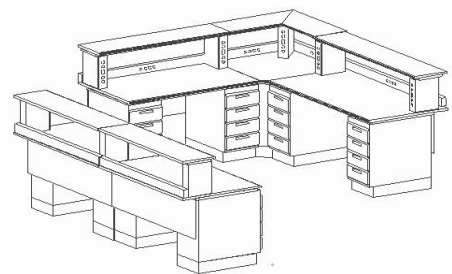
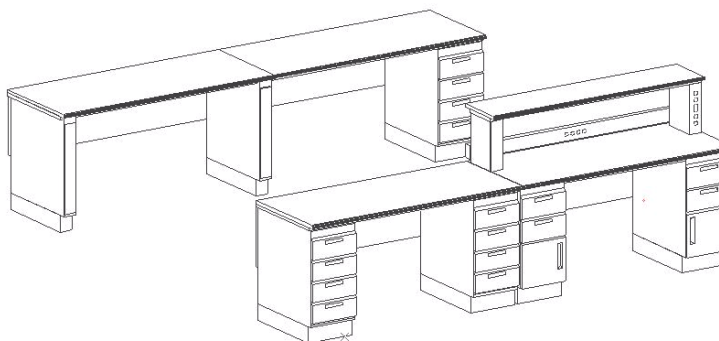
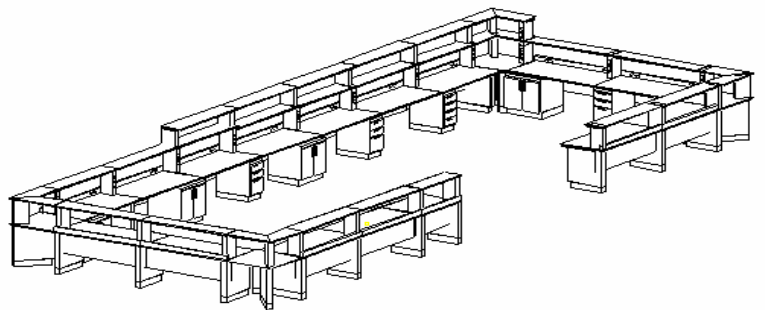
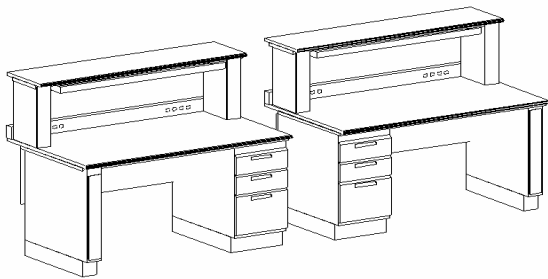

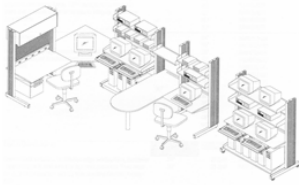

FLEXIBLE Benches & Workstations

From Kewaunee Scientific, Inc.



ADJUSTAbench™ ***Electric Height Adjustment***

- Evolution™ family product
- Electric height adjustable
- Worksurface range 28" – 44" H
- Quick re-set positioning via 3 programmable pre-sets
- 3', 4', 5', 6' standard widths
- 30" or 36" standard depths
- Accepts all accessories, i.e., shelves, lights, drawers, power strips, etc.
- Worksurface & accessories move vertically as one
- 1,000 lb. load capacity
- ESD option
- Extremely quiet, smooth operation



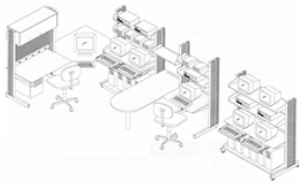

Cleanroom Products

From Kewaunee Scientific, Inc.

Tables, benches, carts, wire rack shelving, workstations, storage and seating for Class 100 clean room environments.

Stainless steel units.

Powder coat finishes for class 1,000+.

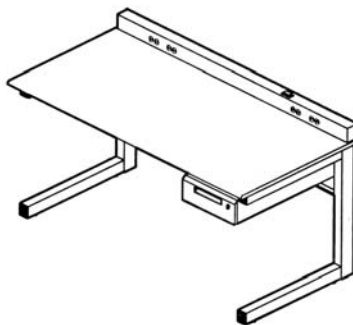
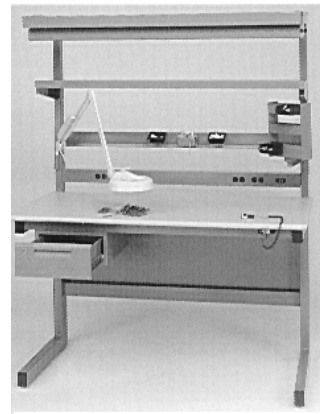

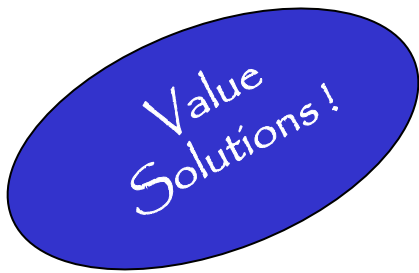

Utility Lab Benches & Workstations

Cost effective heavy-duty benches feature the PB model 4-leg system with telescope support legs, providing manual height adjust range from 30" – 36" (2" increments). 'Price-Right' fixed height C-frame style also available.

- Full radius edge worksurfaces
- 500-800 lb. weight capacity
- 30" & 36" standard depths. 3' – 8' wide
- Typical lead times 2-3 weeks.
- ESD & cleanroom units available
- Resin, maple, S.S. & chemical resistant laminate worksurfaces available
- Multiple powder coat finish choices.
- Full range of standard components, including drawers, cabinets, lighting, power, etc.
- Carts, laminate and steel shelving, laminar flow hoods. Extensive custom capability.
- Quick ship program available. F.O.B., Santa Ana, CA.

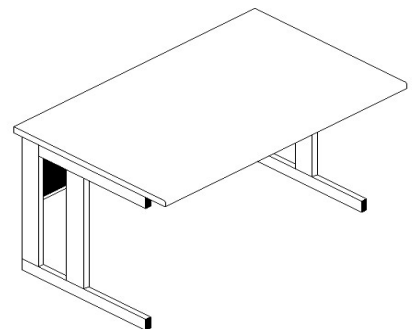
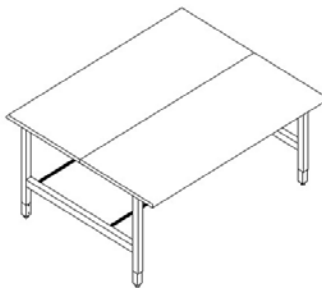

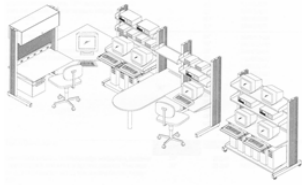

LAN / Network Equipment Cabinets

- 19", 23" or 24" EIA standards for routers, servers and other rack mount equipment
- Full or half door models
- Multiple door & side panel selections, including plexi, mesh or slotted vent
- Heat dissipation fans
- Fixed or slide out shelving
- Multiple depths, heights, colors
- Integrated wire/power
- Optional casters/dolly
- Anti-tilt plate
- 2-3 week typical delivery
- Custom sizes, features



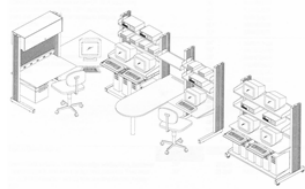

LAB & SPECIALTY SEATING

- Heavy Duty -
- High Comfort -
- 10 yr. Warranty -
- Value Pricing -
- Labs - Engineering
- Production - ESD, etc.



Seating for laboratory, scientific and other technical workspace, including cleanrooms, ESD (electrostatic control), test/assy., manufacturing, engineering, etc. Great comfort, ergo designs, molded 'comfort foam' seats. Excellent value solutions for biotech, electronics, medical, education, data centers, pharmaceutical (including chemical environments) etc. 10 year warranties. F.O.B., Santa Ana, CA. 2 week delivery. Quick ship program.





LAB SEATING GUIDE

Note: All series available in chair or stool versions, with or without adjustable arms. Stools include chrome footrings. The standard base on all models is heavy duty black nylon, 5-star, 24" diameter with dual wheel casters. Other options include Cleanroom/ESD (static control), multi-paddle control upgrades, chrome base, glides, braking casters, conductive casters, custom fabrics, etc.

#550



#1000



#1000 ESD



#2000 C/R



#2050 Stool
Chrome Base



#2050 Stool
Arms-nylon base



#3000



Series	Type/ Adjust	# adj. paddle - std -	Seat size	Back size	Seat/ back mat.	Back adjust	Aval as ESD	Avail. as C/R	Warr.
500 550	Lab/task Height 18-23" or 20"-28"	1	17.75" x18.5"w 2.5" thick	17.25"x16.75" 2.5" thick	Std. foam	fixed	yes	yes	*
600 650	Lab/task Height 18-23" or 20"-28" Back & Seat tilt/adj.	2	17.75" x18.5"w 2.5" thick	17.25"x16.75" 2.5" thick	Std. foam	Up/down 3"	yes	yes	*
700 750	Industrial/ chemical Height 18"-23" or 21"-31"	1	17" x 18.5"w	12.25" x 16"w	Poly- urethane	fixed	yes	yes	*
800 850	Industrial/ chemical Height 18"-23" or 21"-31"	2	17" x 18.5"w	12.25" x 16"w	Poly- urethane	fixed	yes	yes	*
1000 1050	Lab/task Height 18-23" or 20"-28"	1	17" x 20.5"w 3" thick	17.25" x 16.75 2.5" thick	Molded High density foam	Up/down 3"	yes	yes	*
2000 2050	Lab/task Height 18-23" or 20"-28 Back & seat tilt/adjust	2	17" x 20.5"w 3" thick	17.25" x 16.75 2.5" thick	Molded High density foam	Up/down 3"	yes	yes	*
3000 3050	Large lab/task Height 18-23" or 20"-28"	1	19.75" x 20.5" w 3.5" thick	17.25" x 16.75 3" thick	Molded High density foam	Up/down 3"	yes	yes	*
4000 4050	Large lab/task Height 18-23" or 20"-28 Back & seat tilt/adjust	2	19.75" x 20.5"w 3.5" thick	17.25" x 16.75 3" thick	Molded High density foam	yesUp/do wn 3"	yes	yes	*

Note: Choose from fabrics: black, charcoal gray, burgundy, royal blue. Vinyls avail. In black or royal blue. Solid polyurethane chairs and stools (700-800 series) available in black only. * Warranty: Static components, i.e. seat/backrest pans, back bar, std. fabric = lifetime. Ten year warranty for foam, ESD and std. Fabrics and all moving components. Based on 8 hour, 5 day per week shift.

Wire Rack Shelving – Cleanroom Furniture – Carts Healthcare Material Handling - Storage

Our mfg. features the patented QuadTruss wire shelving system, the strongest in the industry. Top surface mat wires are 10% larger than industry standards. Available in chrome (1 year warranty) and *Eaglegard* hybrid epoxy (15 year warranty). Also available in 304 Stainless Steel (15 year warranty) for cleanroom and all other environments

Products include:

Wire rack shelving units, 14", 18", 21" 24" or 36"D. 24", 30", 36", 42", 48", 54", 60" or 72"W. Heights from 7" – 96". Solid shelf systems also available. Fixed or mobile versions. Seismic rated units available.

Stem caster carts: Multiple sizes. Includes shelves and donut bumpers.

Gowning racks

Cleanroom changing benches

Stainless steel tables.

Mobile computer workstations in stainless steel or chrome

Seismic Solutions

Wire Rack



Stem caster cart

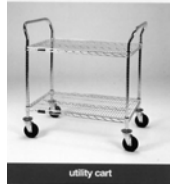

utility cart

AGLE offers hundreds of differently configured mobile shelving systems for retail, industry or home use. Carts can be altered to meet changing requirements. By adding or removing accessories, any number of combinations can be made to customize any cart for a specific use. The open-wire construction promotes higher visibility by allowing light to pass through the shelves, permits freer air circulation reducing dust and contamination buildup, and increases the effectiveness of vibration-suppression systems.

Mobile Shelving Systems

Moving at the speed of life.

Stem caster carts and dolly trucks

- Our patented **QuadTruss**® design makes shelves up to 25% stronger, providing you with the strongest carts in the industry.
- Sturdy, mobile four shelf unit available in either mirror chrome or Eaglebrite® zinc finish.
- Dolly truck comes with complete wraparound bumper.



dolly truck

Visual merchandiser

- Increase product visibility of quick-moving merchandise.
- This unit allows you to adjust and re-adjust shelf heights and angle variances.
- Sturdy, mobile four-shelf unit available in either mirror chrome, Valu-Master® gray epoxy or Eaglebrite® zinc finish.



visual merchandiser

Utility carts

- Patented **QuadTruss**® design makes our shelves up to 25% stronger and provides a retaining ledge for increased storage stability and product retention.
- Individual units available with two wire shelves, three wire shelves or two wire and one solid shelf.
- Finishes offered are mirror chrome or Eaglebrite® zinc finish.

Tote box carrier

- Accommodates a wide variety of containers.
- Custom spacing available and each carrier comes with two brake and two swivel casters.
- Comes standard with three sets of tote box slides constructed of 16 gauge chrome plated steel.
- One-, two-, or three-bay carrier models available with standard resilient or poly casters.



tote box carrier

Also: Healthcare material handling systems, including carts for catheter procedure, suture, linen transport, exchange, etc.

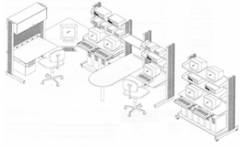

Multi-Media & Secure Storage Cabinets



SECURE LAPTOPS
& Charge Battery
w/ power up option

DDP features the industry's only all steel 'bi-parting' tambour (recess) doors. Ideal, space-saving solution for secure storage of media (tapes, DVDs, etc), devices, computers and other value items & records. Each DDP cabinet is custom populated with a choice of standard storage & shelving components. Abloy, high-security locks on tambour door and on selected internal compartments. Doors operate on ultra-strong aircraft cable. Durable 'Santex' textured coat finish available in black, gray and beige. Simulated wood grain door fronts available for office applications. Full line of media carts and racks. Custom capability. F.O.B., Lockport, NY. 2 week standard delivery. Cabinets ship fully assembled.

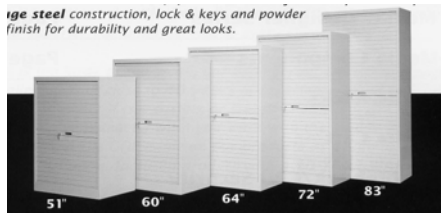

Multi-Media Racks & Cart

Multi-Media Racks
DDP Multi-Media Racks are available in **TWO** heights, 54" & 84" and **Single or Double** sided. Each Multi-Media shelf (#048-00115) is adjustable in 1" increments and comes with 2 adjustable dividers. DDP Multi-Media Racks are 32.5" wide. When adding on to the left or right a common post is used. Standard Colour: BLACK
Optional Colour: BEIGE

54" & 84" Components

#048-00101	54" Single sided post
#048-00102	54" Double sided post
#048-00100	84" Single sided post
#048-00102	84" Double sided post
#048-00145	Joiner bars 1/2" off of (2) 1/4" max. off standard 1/4" increments
#048-00115	Multi-Media Shelf 12" 1/2" (2) dividers, 4" H x 32" W x 3" D
#048-00155	Additional shelf dividers

Media	Capacity	Space
DLT/SDLT	25	6"
DD	28	6"
CD/DVD	78	7"
4MM	52	7"
8MM	40	5"
1/2" VHS	51	5"
3/4" VHS	30	6"
Chassis 5.25"	45	7"
3480/3490	32	6"

Multi-Media Mobile Cart
DDP #050-40000 40" H x 33.5" W x 30.5" D
The DDP Mobile Cart comes complete with a total of (8) Media shelves and (16) Dividers. Manufactured with quality and durability in mind the DDP Media Cart comes complete with heavy duty casters and corner bumpers. The Multi-Media shelves are adjustable in 1" increments. The capacities per shelf are the same as the above multi-media shelves.

Standard Colour: BLACK

10

Application Notes:

Healthcare industries following HIPPA, the Federal Act regulating medical record privacy and control, specify DDP cabinets to help support compliance.

Military and law enforcement agencies specify DDP cabinets for secure weapons storage.

News Item. Associated Press 6/11/04

Laptop theft puts donor IDs at risk

Tens of thousands of UCLA blood donors have been notified that they are at risk of identity theft because a stolen laptop computer contained their SS numbers, birthdates & other personal information....

Laminar Flow Hoods

Horizontal & Vertical Units
for Class 100 Operations



Flat Panel Monitor Arms



Optimize sightline ergonomics for flat panel displays in lab environments. We offer a comprehensive selection of heavy duty units with a wide range of adjustment and range capabilities. Mount to walls, worksurfaces or bench columns (e.g. Kewaunee Evolution**).

Adjustable arms with platforms for scopes, VDTs, keyboards etc. also available.

Partial End-User Customer List:

Bayer Hitachi Data Sony Guidant Medical Intel
BioRad Labs Yahoo National Semi Sandia Citibank
Avaya Apple Computer Rambus Semi Marvell Semiconductor
AampMobile UCSF LSI Logic Lawrence Berkeley National Labs
Synopsys Hewlett Packard McData DeVry Institute
Sling Media Volcano Therapeutics Cuesta College Lockheed
US Navy Sprint Travis AFB Volkswagen Research

JHA Techspace represents, distributes, specifies and installs products & systems from high quality manufacturers with solid reputations and experience. We're available to visit the site of your project and consult on layout, workflow, configurations, design specs. etc. There is no charge for this service.

After evaluating requirements, we prepare specs and/or layout drawings to further the process of defining an optimal solution.

Contacts us for directly by phone, email, fax, or visit our website.

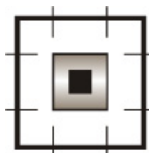

JHA Techspace

Flexible Furniture Solutions

Technology Laboratory Office

e - jack@jha-techspace.com

p - 415.285.4700

w - www.jha-techspace.com

f - 415.285.4066

p.o. box 411561 S.F. CA 94141

Representing Kewaunee Scientific, Inc.