

EVOLUTION—BASIC WORKSTATION INSTALLATION

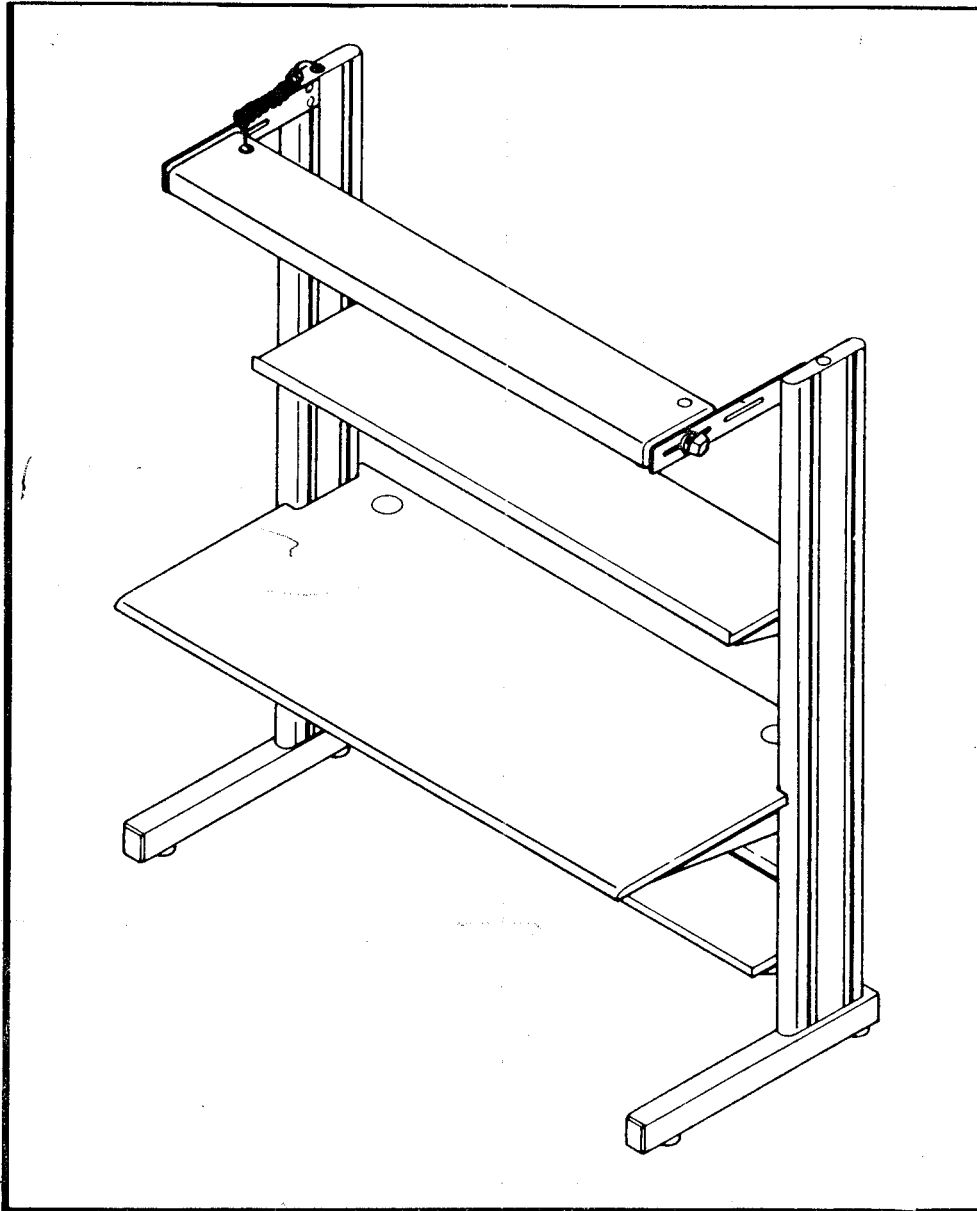

KEWAUNEE
Scientific
Corporation

901 FM 20, P.O. Box 930, Lockhart, TX 78644-0930
(512) 398-5292, Toll Free in U.S. 800-824-6626

PART NO. 990642

EVOLUTION—BASIC WORKSTATION INSTALLATION

SUPPORT BRACKET
TASK LIGHT/TOOL BAR

TASK LIGHT

COLUMN

ACCENT STRIP

SHELF

WORKSURFACE

APRON

SUPPORT BRACKET,
WORKSURFACE

MODESTY PANEL

SHELF

SUPPORT BRACKET,
SHELF

PRODUCT VOCABULARY

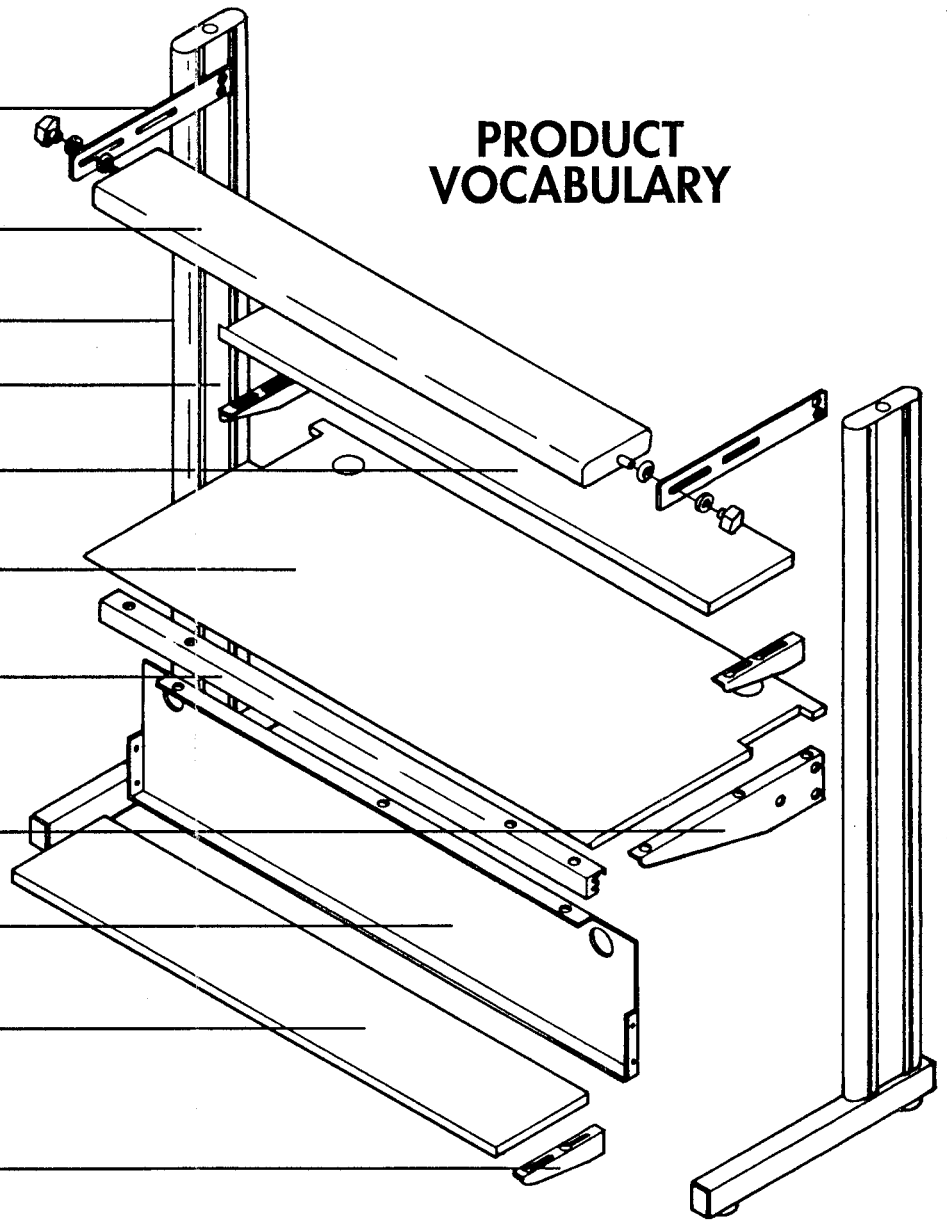
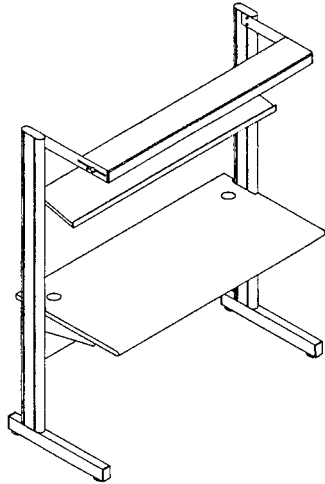

TABLE OF CONTENTS

PAGE SUBJECT	PAGE SUBJECT
2 Product Vocabulary	7 Double-Sided Worksurface Support Double-Sided Modesty Panel
3 Workstation Variations	8 Shelving Apron Spreader
4 Assembly Preparation Recommended Tools	9 Single-Sided Worksurface Double-Sided Worksurface
5 Attachment Bolts Lower Leg Assembly	10 Wiring Harness Accent Strip
6 Single-Sided Worksurface Support Single-Sided Modesty Panel	11 Task Light Task Light—Multiple

WORKSTATION VARIATIONS



**SINGLE-SIDED
WORKSTATION**

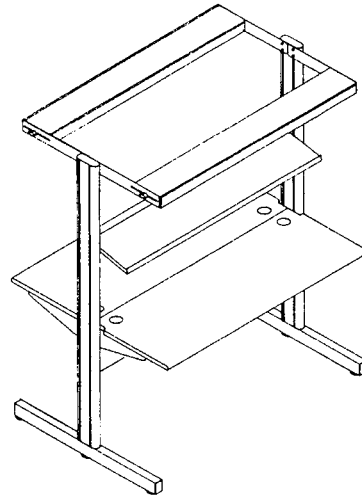

**DOUBLE-SIDED
WORKSTATION**

**FREE-STANDING WORKSTATIONS
WITH LIGHT AND SHELF ACCESSORY**

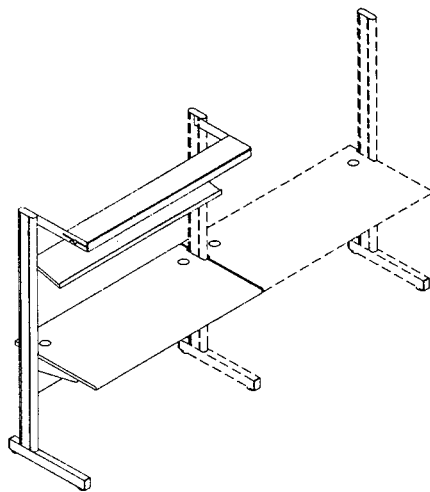

**ADD-ON WORKSTATIONS
WITH LIGHT AND SHELF ACCESSORY**

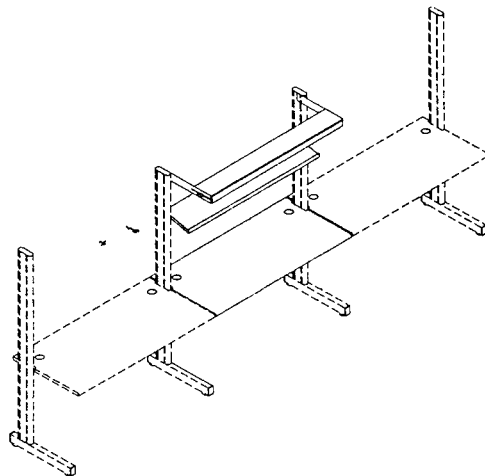

**BRIDGE WORKSTATIONS
WITH LIGHT AND SHELF ACCESSORY**

EVOLUTION—BASIC WORKSTATION INSTALLATION

ASSEMBLY PREPARATION

Kewaunee Scientific products are inspected and packaged carefully. As you open the carton, be careful not to damage the products inside if cutting tools are used.

Many items have been factory assembled for your convenience. Hardware packs are included with each item requiring assembly.

Task lighting, shelving and column electrics have been included in the basic workstation instructions. All other accessories are shown separately.

Unpack all parts for each workstation assembly required.

Basic workstation will consist of:

1. Worksurface assembly complete with worksurface supports, modesty panel, apron and hardware pack.
2. Two column assemblies with leg bases and hardware pack.

Add-on workstation will consist of:

1. Worksurface assembly complete with worksurface, support, modesty panel, apron and hardware pack.
2. One column assembly with leg base and hardware pack.

Bridge workstation will consist of:

Worksurface assembly complete with worksurface, support, modesty panel, apron, and hardware pack.

Review the following pages for step-by-step instructions before starting the assembly.

RECOMMENDED TOOLS

- Screwdriver (Phillips type)
- 3/8" Open-End Wrench
- 7/16" Open-End Wrench
- 1/2" Open-End Wrench
- 3/8" Socket with Ratchet Handle
- Level (for leveling worksurface/shelf)

IF YOU NEED ANY ASSISTANCE,
contact Kewaunee Service department at 1-800-824-6626.

EVOLUTION—BASIC WORKSTATION INSTALLATION

1. ATTACHMENT BOLTS

Stud plates for attaching work top supports should be inserted into the column.

- A single-sided workstation will require (1) stud plate on the left column and (1) bolt on the right.

The right side column is shown. Reverse procedure for the left column. The basic workstation will require both left and right column assemblies.

- A double-sided workstation will require (1) stud plate for each column.

NOTE: Additional bolts can be added above the worksurface for custom accessory attachment before the light support is installed.

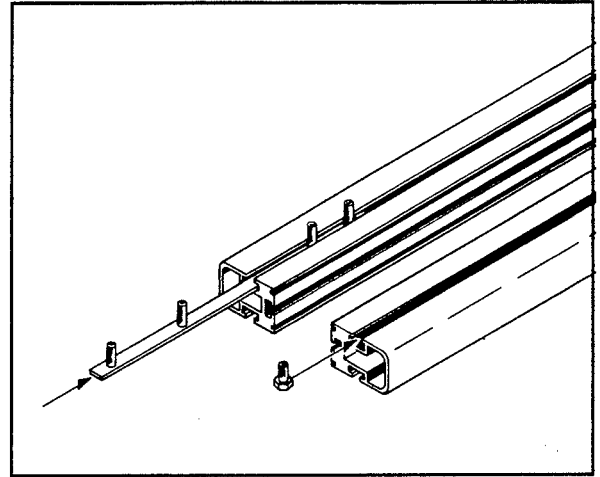

FIGURE 1

2. LOWER LEG ASSEMBLY

The lower leg requires (2) stud plates with nuts and washers. The stud plates should face outwards with the washer and nut on the inside of the channel. Do not tighten bolts, connect only.

Slide the leg assembly into the slots in the inside of the column and tighten using a 1/2" wrench.

Do not over tighten.

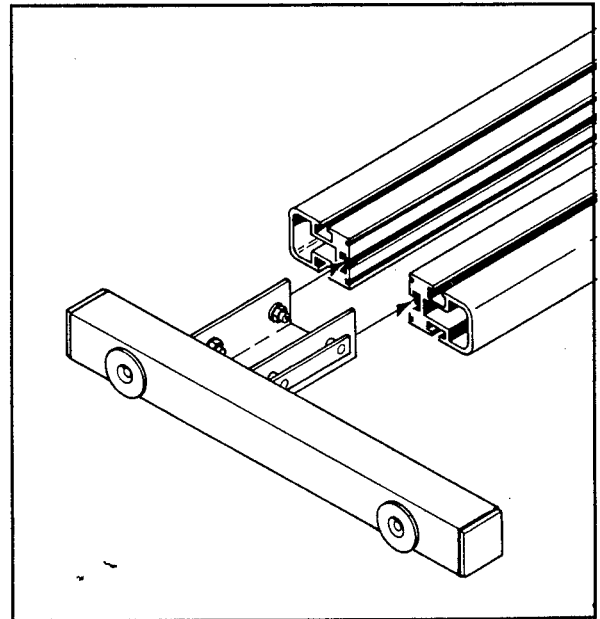

FIGURE 2

EVOLUTION—BASIC WORKSTATION INSTALLATION

3. SINGLE-SIDED WORKSURFACE SUPPORT

To attach the support to the column (3) cap nuts with washers are required.

Determine the height of your workstation:

- When a sitting height worksurface is required ... measure 25 3/16" from the column base to the top of the support.
- When a standing height worksurface is required ... measure 31 3/16" from the column base to the top of the support.

Lay the completed column on a flat surface and mark the desired worksurface height. Place the support on the column and attach with (3) black acorn nuts and washers using a wrench. Do not over tighten.

Care should be taken to insure the support is perpendicular to the column.

NOTE: For in line systems brackets will be required on both sides of the column.

4. SINGLE-SIDED MODESTY PANEL

Stand column upright and set modesty panel into position. The top of the panel must be flush with top of the worksurface support. Attach with black acorn nuts with washers using a 1/2" wrench.

Shelving supports may also be added at this time. Shelving can be on either a flat or sloping plane. Shelving will be perpendicular with the columns if the lower rear hole is used. Shelving will have a 15° slope if the lower front hole is used.

Use the T-bolts and black acorn nuts with flat washers included in the shelf hardware pack. Attach using a 1/2" wrench.

Do not over tighten.

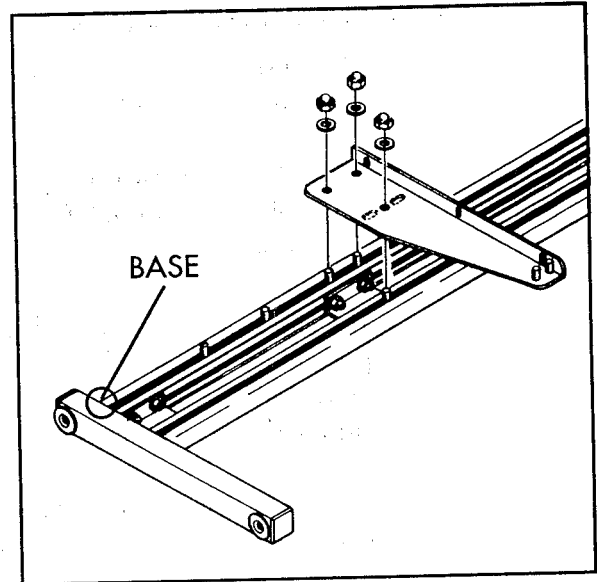

FIGURE 3

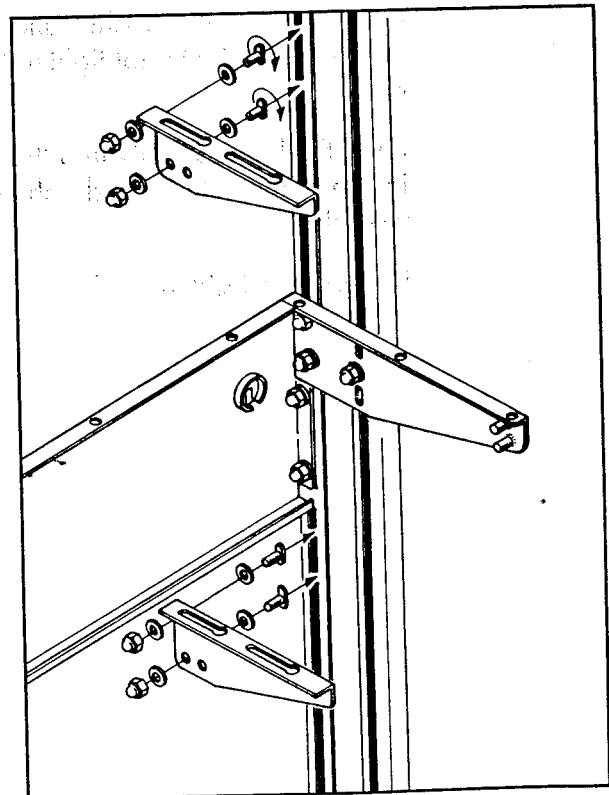

FIGURE 4

EVOLUTION—BASIC WORKSTATION INSTALLATION

5. DOUBLE-SIDED WORKSURFACE SUPPORT

To attach the support to the column (4) cap nuts with washers are required.

Determine the height of your workstation:

- When a sitting height worksurface is required ... measure $25 \frac{3}{16}$ " from the column base to the top of the support.
- When a standing height worksurface is required ... measure $31 \frac{3}{16}$ " from the column base to the top of the support.

Lay the completed column on a flat surface and mark the desired worksurface height. Place the support on the column and attach with (4) black acorn nuts and washers. Do not over tighten.

Care should be taken to insure the support is perpendicular to the column.

NOTE: For in-line systems, brackets will be required on both sides of the column.

6. DOUBLE-SIDED MODESTY PANEL

Stand column upright and set modesty panels into position. The top of the panel must be flush with top of the worksurface support. Attach with black acorn nuts with washers using a $\frac{1}{2}$ " wrench. Do not over tighten.

Shelving supports may also be added at this time. Shelving can be on either a flat or sloping plane. Shelving will be perpendicular with the columns if the lower rear hole is used. Shelving will have a 15° slope if the lower front hole is used.

Use the T-bolts and black acorn nuts with flat washers included in the shelf hardware pack. Attach using a $\frac{1}{2}$ " wrench.

Do not over tighten.

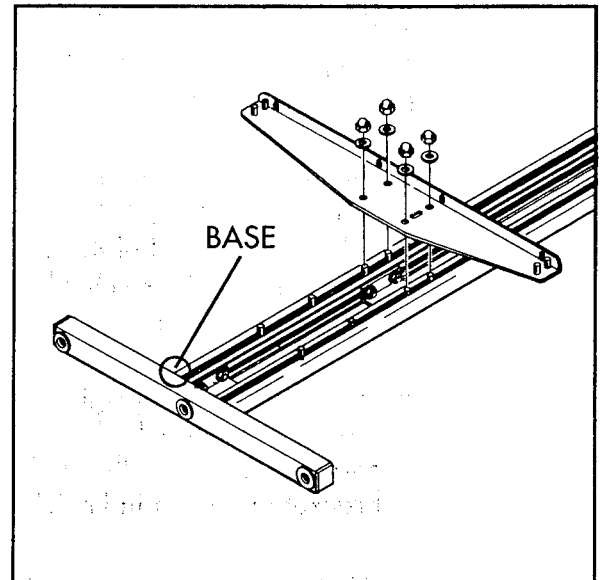

FIGURE 5 (BASE)

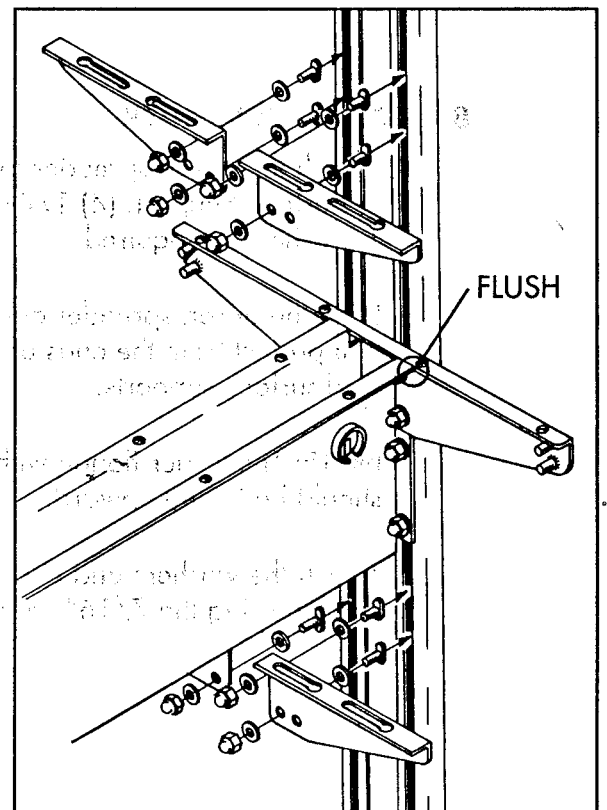

FIGURE 6

EVOLUTION—BASIC WORKSTATION INSTALLATION

7. SHELVING

To attach the shelf to the shelf support, (4) 3/8" thread-forming screws are required.

- Lay the shelf upside down on a flat surface. Insert the 3/8" screws into the holes at each end of the shelf using the 3/8" socket with ratchet handle. Do not tighten at this time.
- Place shelf in an upright position. Insert screw heads into the large opening at the end of each slot in the shelf support bracket as shown in FIGURE 7.
- Adjust shelf to desired location and tighten screws using the 3/8" wrench.
- Use a level to determine that shelf is equal in height at both ends. To adjust, move shelf support to the correct location.

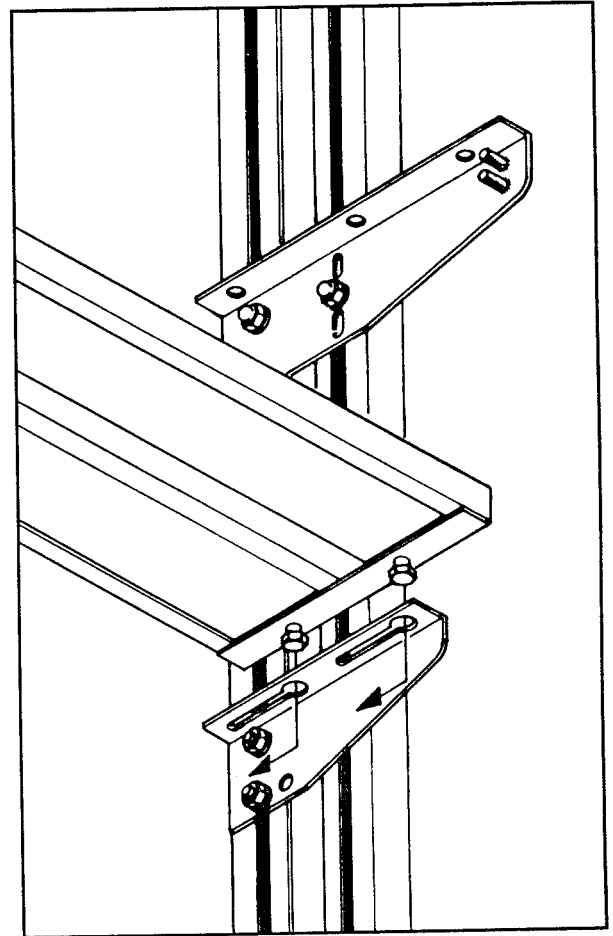

FIGURE 7

8. APRON SPREADER

To attach the apron spreader to the Worksurface Support, (4) 1/4-20 Hex Nuts with washer are required.

- Slide the apron spreader onto the studs that project from the ends of the worksurface supports.

NOTE: The larger flange with holes should be facing upward.

- Attach the washers and nuts to the studs. Tighten using the 7/16" wrench.

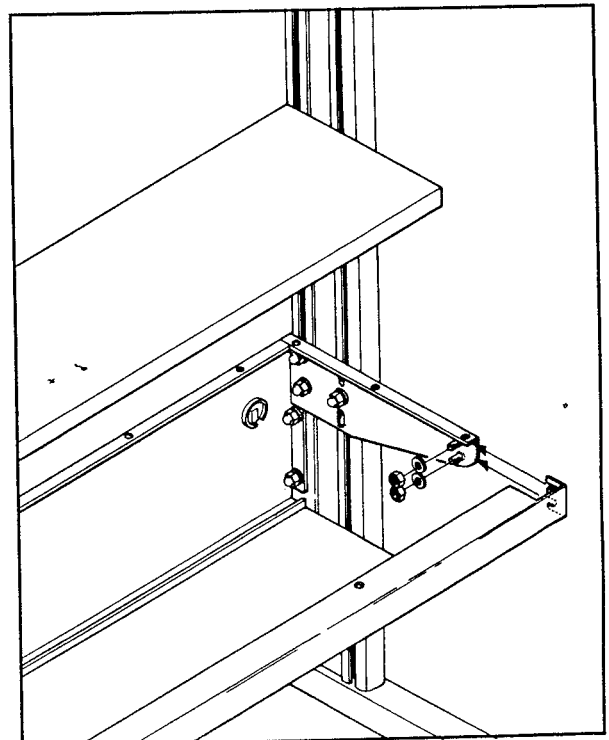

FIGURE 8

EVOLUTION—BASIC WORKSTATION INSTALLATION

9. SINGLE-SIDED WORKSURFACE

- Tilt the worksurface, then lower one end at a time until the worksurface rests flat on top of the supports, apron panel, and modesty panel.
- Threaded steel inserts have been supplied in the underside of the worksurface. Align inserts with holes in the supports, then hand-insert the 1/4-20 screws.
- Align worksurface to columns (and other worksurfaces, if in-line system is used). Tighten screws with the Phillips screwdriver. Use a level to determine that the worksurface is level. To adjust worksurface location, move support and modesty panel at one end.

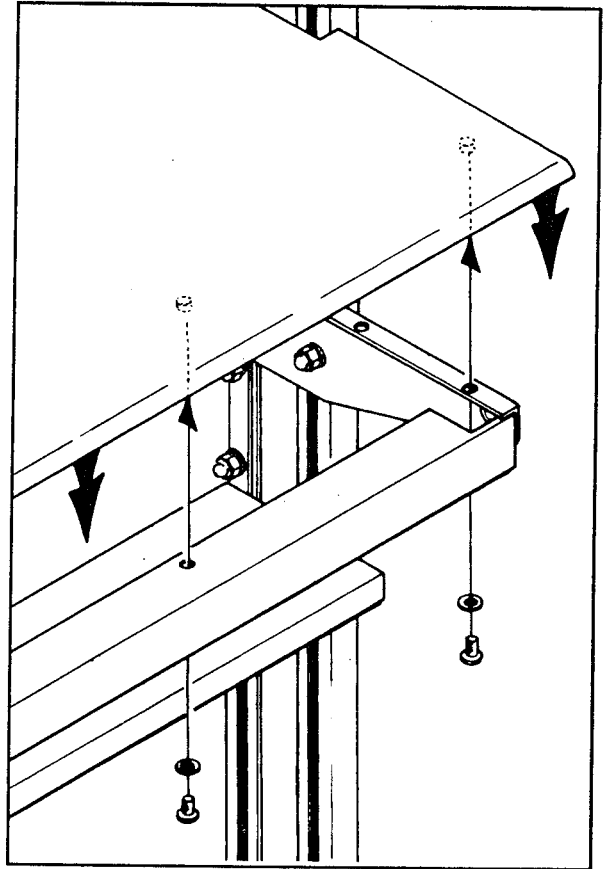

FIGURE 9

10. DOUBLE-SIDED WORKSURFACE

- Tilt the worksurface, then lower one end at a time until the worksurface rests flat on top of the supports. Repeat for the adjoining worksurface.
- Align both worksurfaces with the holes in the supports, Hand insert 1/4-20 screws.
- Align worksurface to column (and other worksurfaces, if in-line system is used). Tighten screws using the Phillips screwdriver.
- Use a level to determine that both worksurfaces are level. To adjust worksurface location, move support and modesty panel at one end.

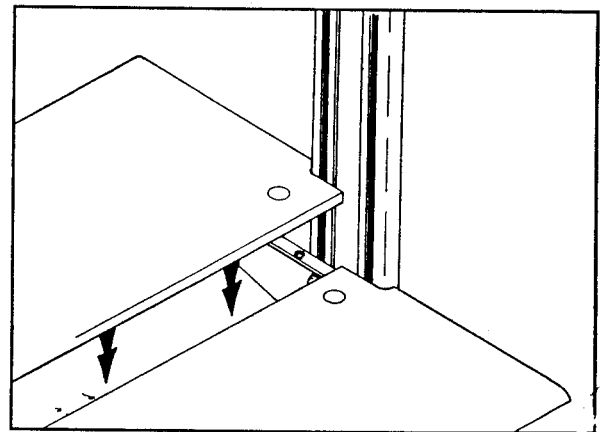

FIGURE 10

EVOLUTION—BASIC WORKSTATION INSTALLATION

11. WIRING HARNESS

One accent color insert should be removed on the column that will contain the power connections.

Remove the column cap using the Phillips screw driver.

Remove the laminate accent strip.

Insert the power cord into the strain relief plate then snap in strain the relief bushing.

- Place the wiring harness inside the column leaving the single hook up at the top of the column as shown. Connect the power cord to the harness; **green to green and black/white to black/white.**

NOTE: An additional hook up is included for connection to accessories. Connectors are rated for 20 amp circuits.

12. ACCENT STRIP

Accent strips should be inserted or reinserted into the column.

The task light connectors should project above the column.

Do not attach the column cap at this time.

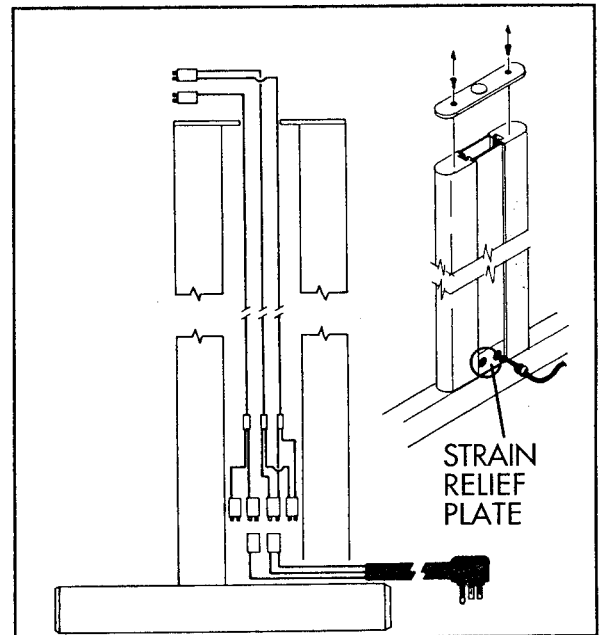

FIGURE 11

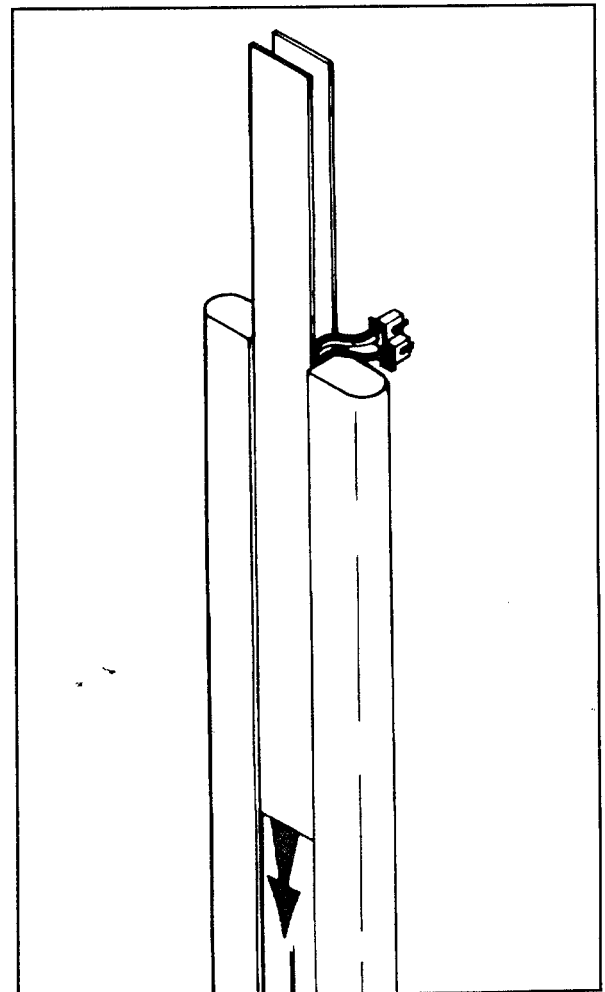

FIGURE 12

EVOLUTION—BASIC WORKSTATION INSTALLATION

13. TASK LIGHT

Slide two 5/16 hex bolts into the mounting slot. Determine desired height. With the black acorn nuts and washer attach the light supports to the column using a 1/2" wrench. Do not over tighten.

- Place a thick rubber washer on the stud at each end of the light.

Insert light onto bracket; place a thin washer on the stud, then secure with hand knob.

- To connect the light, feed the cable connectors on the power cord through the cap and snap in the strain relief bushing. Join the electric connectors together; **green to green and black/white to black/white**. Then carefully insert excess wire into column.

Fasten cap to column with screws using the Phillips screw driver.

- Join the connectors at the light and insert into light body. Snap in the strain relief bushing.

Each task light is supplied with connectors at each end. Insert the unused connectors into the light body and cover hole using the snap-in hole plug supplied in the hardware package.

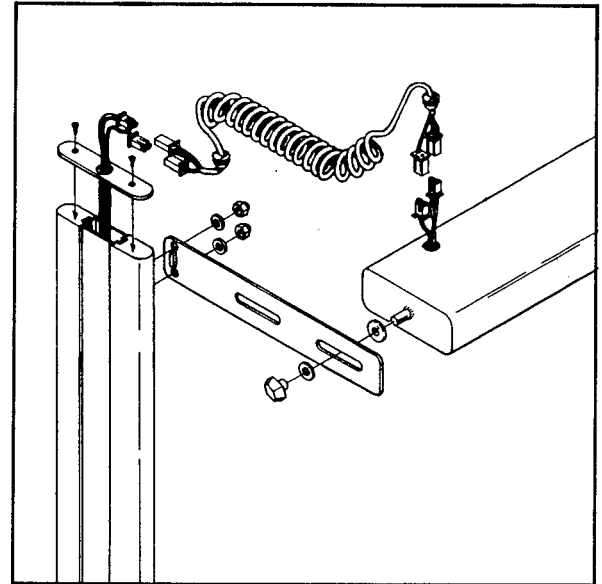

FIGURE 13

14. TASK LIGHT—MULTIPLE

Task lights can be powered with one source by connecting lights in series. Use the power cord supplied with each task light as shown in Figure 14. (A double-sided bench is shown. If your workstations are single in-line systems, the task lights can similarly be connected in series.)

When more than one circuit is required, an additional power cord should be added for each additional circuit desired.

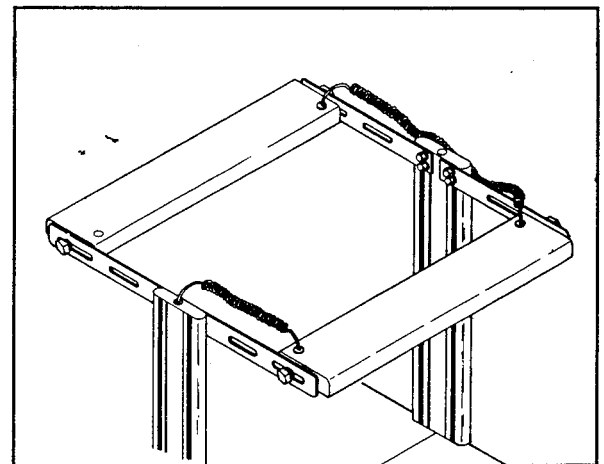

FIGURE 14

BIN BAR ASSEMBLY

Bin bars may be mounted in front or rear of the column. Rear column mount shown in fig. 1.

- Install the bin bar brackets. The offset bend should be toward the center of the workstation, and the notches should be open to the top.
- Open the hardware package and remove the hardware. Insert the T-bolts through the holes in each bracket. Insert the metal washer and thread the acorn nuts onto the T-bolts, approximately one full thread.

See fig. 1 for single sided application.

See fig. 2 for double sided application.

Install each bracket at the desired height by inserting the T-bolts into the column T-slots from the side of the column, and rotating clockwise. Tighten the acorn nuts.

- Install the bin bar in the desired horizontal location.

ESD BIN BAR GROUNDING

- ESD bin bars are constructed from conductive material and must be grounded.
- Connect the small ring terminal on the ground wire to the bin bar with green ground screw provided.
(See fig. 2)
- Connect the large ring terminal to worksurface ground bolt, or equivalent common point ground.

RECOMMENDED TOOLS

Screwdriver (Flat blade type) @ Ground screw
1/2" Open-End Wrench

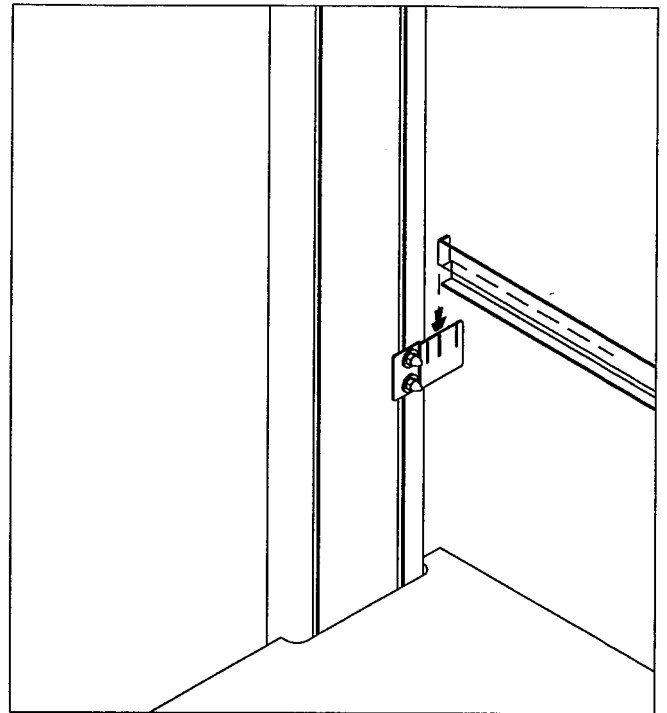

FIGURE 1

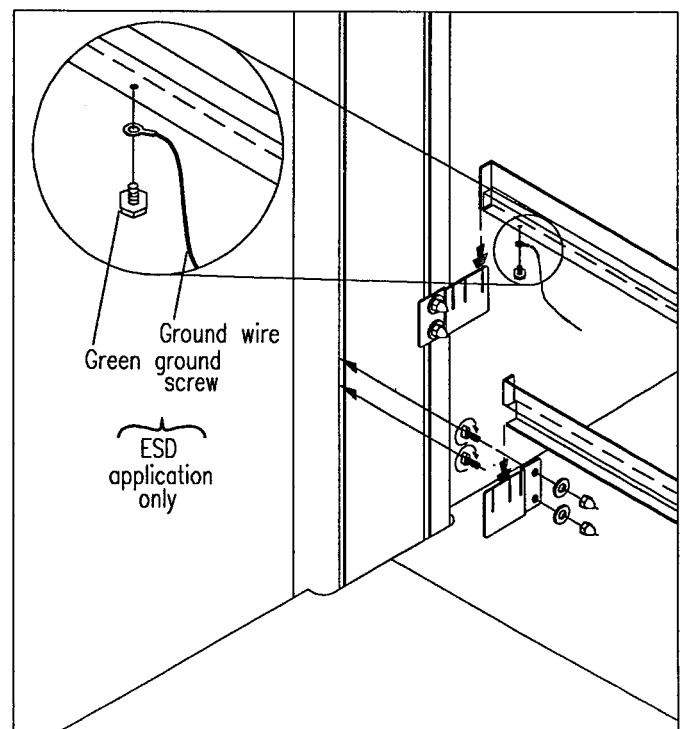

FIGURE 2

POWER DISTRIBUTION CHANNEL

- Locate holes to be drilled. (See fig. 1)
- Drill four (4) 5/16" diameter holes. Drill slowly until the drill has passed through the laminate coating.
- Remove one lower screw and pivot the column cap to insert the 1/4-20 bolts as shown. Replace the screw, then align the bolts with the 5/16" holes, add washers with nuts and tighten.

For ESD power distribution channels, install the insulation paper between the channel and the worksurface. (See fig. 2)

Connect the power jumper to the desired end. Push the connectors inside the channel. Install the strain relief bushing from the hardware package. If not jumping to an adjacent channel, install the hole plug from the hardware package into the other end of the channel.

It is recommended that only authorized electric technicians be responsible for final connections.

- Route the channel jumper down to the strain relief plate, and insert through the plate into the column.
- Connect the jumper to the column harness, matching the wire colors. Install the strain relief bushing from the hardware package.

RECOMMENDED TOOLS

screwdriver (Phillips type)
7/16" Open-End Wrench

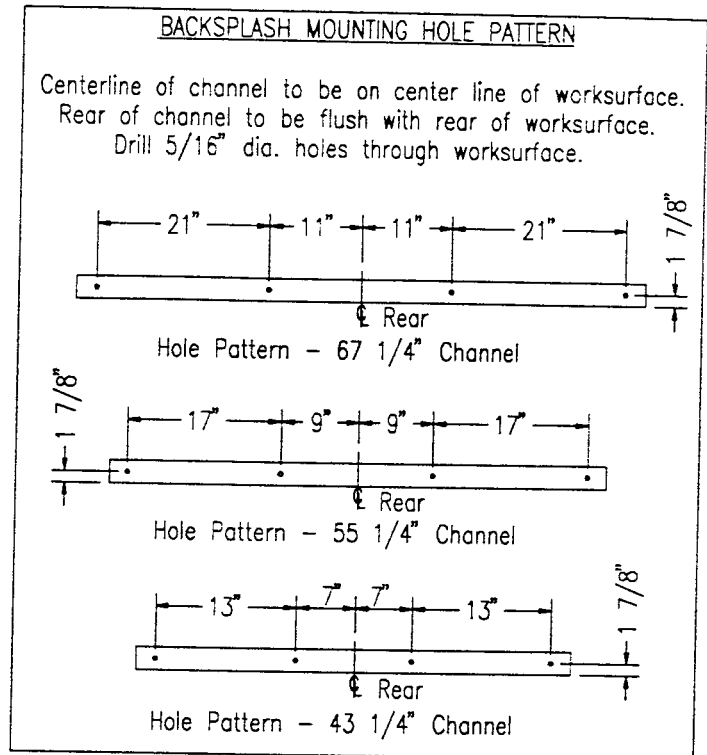

FIGURE 1

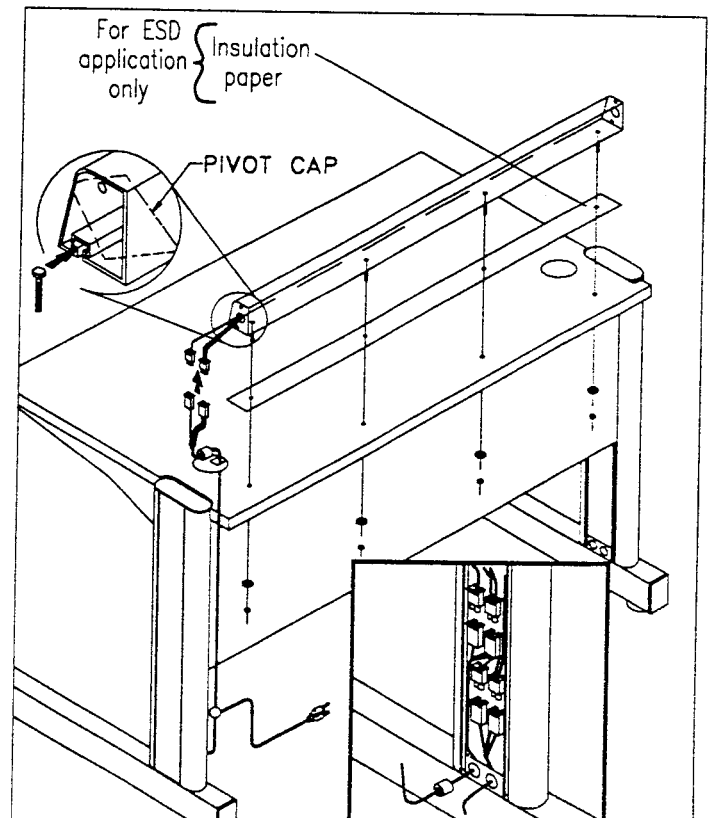

FIGURE 2

STATIC DISSIPATIVE SURFACE GROUNDING INSTRUCTIONS

Note: This kit contains two Stainless Steel bolts. Only one of the bolts is to be used for ground connections. The other is to be used to verify continuity of the ground bolt.

Figure A

- 1) Using a dull 5/16" drill bit, drill two holes in the ESD surface approximately 3" apart. Be sure the location chosen will not interfere with parts under the surface (hanging drawers, utility channels, frames, etc).
- 2) Shake the bottle of conductive paint well. Coat the splines of the Stainless Steel ground bolts with the conductive paint and insert the bolts into the holes.

Figure B

- 1) Install a flat washer and nut on each of the ground bolts and tighten.
- 2) Using an ohmmeter, check for continuity between the two bolts. A finite reading indicates contact of the bolts to the conductive layer in the worksurface.
- 3) On one of the Stainless Steel bolts, install the ground wire, washer, and nut and tighten.

A shelf ground wire is to be connected between the shelf ground bolt and the worksurface ground bolt. A worksurface ground wire is to be connected between the worksurface ground bolt and facilities ground.

Figure C and D

- 1) Connection to facility ground is accomplished by either of the methods illustrated in Figure C or D.

Note: If Figure C method is used, verify proper connection of facility ground.

FIGURE 'B'

TYPICAL WIRE CONNECTION AT GROUND BOLT (UNDER SURFACE)

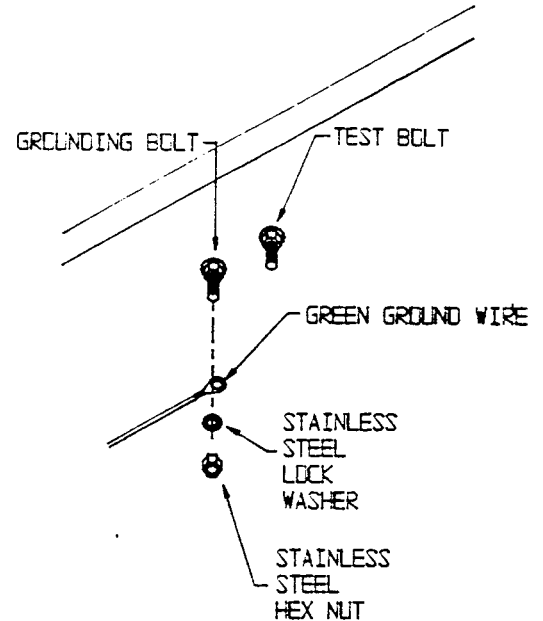

FIGURE 'C'

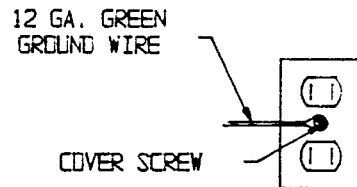

FIGURE 'A'

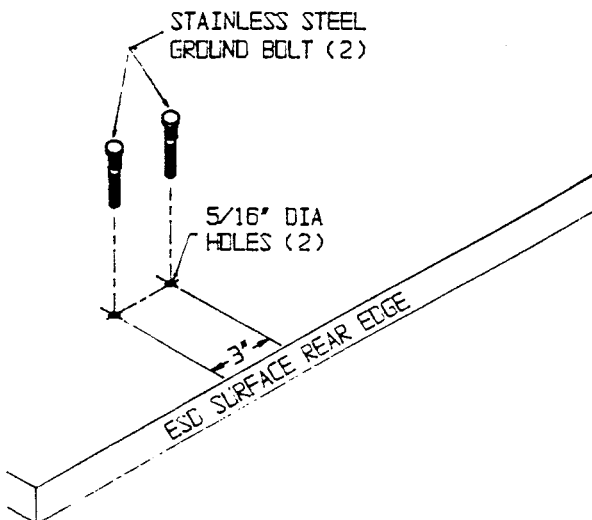

FIGURE 'D'

